

Series **FLOATER**

• Oil Transport



To handle hose in off-shore or shallow harbor operations

Hannay Floater reels are custom-made and designed with special features to efficiently handle floater hose in off-shore boat to barge, and ship to shore operations. The heavy-duty design and construction ensure that the reel stands up to harsh environments and outlasts the competition.

Standard floater reel construction includes:

- 3" square tubing frames, braced at all stress points
- Heavy-duty 1/4" thick plate rolled discs with large rolled edges to avoid hose scuffing
- Drum features an open pipe spacer design with inner 3/8" steel plate reinforcements to prevent the entrapment of dirt, debris, and water accumulation
- Heavy-duty lubricated bearings
- Four lifting eyes or optional fork rails for transportation and installation
- Positive pin-lock to keep the reel in place
- 1/2" air evacuation drain
- Hydraulic caliper disc brake
- #50 chain and sprocket rewind system; optional #80 chain available
- MNPT or flange connection; optional cam lock fittings available
- Available with gear reductions, clutches, and brake systems to handle 3", 4", 6", 8", or 10" I.D. hose
- Marine grade finish



Floater reel shown with electric rewind (hose not included)



Floater reel shown with hydraulic rewind

Series FLOATER

• Oil Transport



How to order:

All floater reels are built to order for varying applications. When ordering, please provide the following information:

1. Specify the complete model number and type of rewind; include prefix E for electric rewind motor, A for air, HD for hydraulic
2. Indicate hose size: I.D., flat dimension, and length of hose
3. Indicate the type of hose connection
4. Indicate if hydraulic power unit is needed

Model Number	Hose Capacity in Feet (one continuous length)						Reel Dimensions in Inches E, F, and G are Overall Dimensions							
	I.D.	3"	4"	6"	8"	10"	A	B	C	D	E	F	G	H
	Flat Dim.	1-3/4" x 5"	2" x 6-1/2"	3" x 10"	3-1/2" x 12"	3-1/2" x 14"								
C350-45-49-20		250	-	-	-	-	50.25	36	20	45.75	45	64.75	49	26.5
C362-45-49-20		350	-	-	-	-	62.25	48	20	45.75	45	76.75	49	26.5
C356-56-60-24		500	-	-	-	-	56.25	42	24	56.75	56	70.75	60	32
C370-56-60-24		750	-	-	-	-	70.25	56	24	56.75	56	84.75	60	32
C380-62-66-30		1000	-	-	-	-	80.25	66	30	62.75	62	94.75	66	35
C456-56-60-36		-	200	-	-	-	56.25	42	36	56.75	56	70.75	60	32
C480-56-60-36		-	400	-	-	-	80.25	66	36	56.75	56	94.75	60	32
C480-62-66-36		-	500	-	-	-	80.25	66	36	62.75	62	94.75	66	35
C480-66-70-36		-	650	-	-	-	80.25	66	36	66.75	66	94.75	70	37
C480-72-76-36		-	750	-	-	-	80.25	66	36	72.75	72	94.75	76	40
C486-72-76-36		-	1000	-	-	-	86.25	72	36	72.75	72	100.75	76	40
C486-84-88-36		-	1500	-	-	-	86.25	72	36	84.75	84	100.75	88	46
C666-72-76-48		-	-	200	-	-	66.25	52	48	72.75	72	80.75	76	40
C674-84-88-46		-	-	350	-	-	74.25	60	48	84.75	84	88.75	88	46
C686-84-88-48		-	-	500	-	-	86.25	72	48	84.75	84	100.75	88	46
C686-90-94-48		-	-	650	-	-	86.25	72	48	90.75	90	100.75	94	49
C6108-90-94-48		-	-	750	-	-	108.25	94	46	90.75	90	122.75	94	49
C6118-90-94-48		-	-	900	-	-	118.25	104	46	90.75	90	132.75	94	49
C898-90-94-48		-	-	-	500	-	98.25	84	46	90.75	90	112.75	94	49
C8124-90-94-48		-	-	-	650	-	124.25	110	48	90.75	90	138.75	94	49
C8148-90-94-48		-	-	-	900	-	148.25	134	48	90.75	90	162.75	94	49
C10114-90-94-48		-	-	-	-	500	114.25	100	48	90.75	90	128.75	94	49

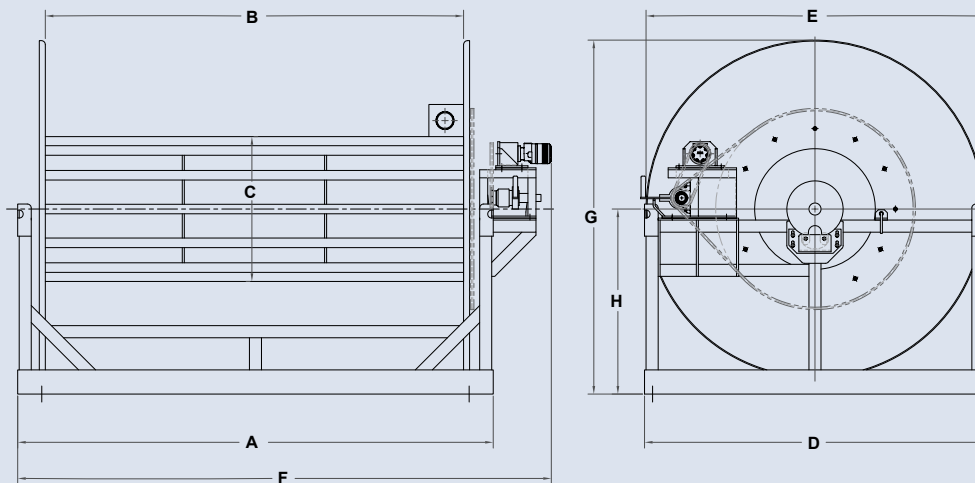

Series **BOOM**

• Oil Containment



To handle all types of containment boom

Hannay Boom reels are custom-made and designed with special features to maximize performance and ease of installation on docks, ships, and oil rigs. Hannay Boom reels can handle various types of booms including flotation logs and inflatable, collapsible, and flexible cylinder boom. Reel capacity is crafted for each application and type of boom to be used.

Standard boom reel construction includes:

- 3" square tubing frames, braced at all stress points
- Heavy-duty 1/4" thick plate rolled discs
- Drum features an open pipe spacer design with inner 3/8" steel plate reinforcements to prevent entrapment of dirt, debris, and water accumulation
- Heavy-duty lubricated bearings
- Four lifting eyes or optional fork rails for transportation and installation
- Positive pin-lock to keep the reel in place
- #50 chain and sprocket rewind system
- Marine grade finish
- Available with gear reductions, clutches, and brake systems for maximum rewind power, speed of deployment, and control – specify requirements needed

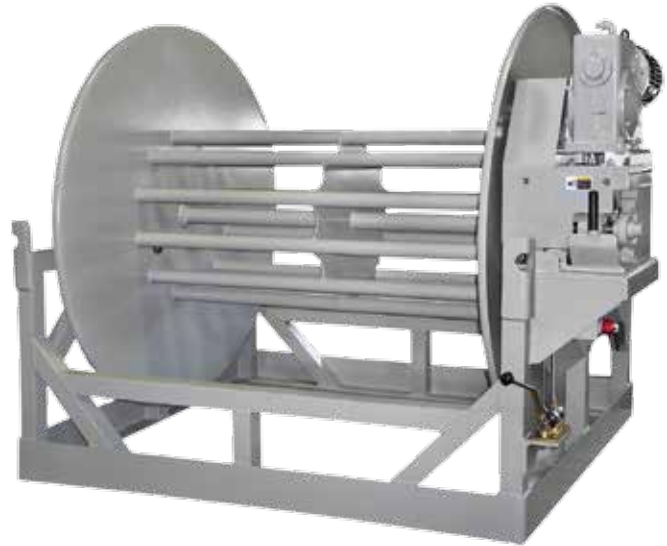

Standard configuration shown with electric rewind motor

How to order:

All boom reels are built to order for varying applications and types of boom. When ordering, please provide the following information:

1. Describe location and usage
2. Specify boom type, size, bending radius, and volume for each length
3. Specify total length of boom
4. Specify type of rewind: hydraulic, electric, or air
5. Specify speed requirements (ie: average feet per minute)
6. Specify necessary accessories (ie: brake controls, fork rails, hydraulic power unit, etc.)

